

S30



## Mid-sized Rider Sweeper

- Deliver unrivaled sweeping performance and dry dust control with 3-stage SweepSmart™ system
- Clean indoors and out, without compromising performance
- Improve operator safety with low 80 dBA noise rating and innovative cab forward design



# The quietest, most productive indoor/outdoor sweeper available



Engineered for reliable, industrial-strength sweeping, the Tennant S30 rider sweeper improves indoor and outdoor performance, significantly reduces sound levels and features the exclusive SweepSmart™ dust control system.

## Significantly improve air quality

Create cleaner air while delivering better sweeping results with the SweepSmart™ dust control system. This 3-stage system filters sub-micron dust particles to a MERV 13 rating on the ASHRAE 20 point scale, resulting in near HEPA levels.

## Unrivaled sweeping performance

Easily pick-up everything from fine grains of sand to light debris on almost any terrain or floor surface. The Tennant S30 offers true indoor/outdoor flexibility while delivering exceptional cleaning results.

## Unparalleled safety

Focusing on safety, the Tennant S30 provides better operator sightlines, reduced noise levels, and easy operation. This is achieved with a cab forward design, key material and system improvements, and recognized by Underwriter's Laboratory (UL®) stamp of approval.

## Reliably provide a clean, safe, and productive environment with SweepSmart™

Improving air flow filtration and dust control for sweeping, the patent-pending S30 SweepSmart™ system uses a **3-stage dust control system** for unrivaled performance:



### STAGE 1

Keep bulky debris, moisture and dirt in the hopper with the *first stage Perma-Filter™*.

### STAGE 2

Remove fine dust and moisture by redirecting it into the hopper with the *second stage cyclonic filters*.

### STAGE 3

Filter sub-micron dust particulates down to 0.5 microns at 99% efficiency with a *third stage, flame retardant, nanofiber canister filter*.



## PRODUCTIVE. CLEAN. SAFE.



Reduce downtime, service time, and maintenance costs by quickly accessing the heart of the S30 with EasyOpen™ service access.



Engineered, fiber-reinforced composite covers are light weight, corrosion resistant, and manufactured with a high-density material. The superior finish makes these covers easy to clean and restorable even if damaged.



Enhance operator safety and productivity with a cab forward ErgoSpace™ operator compartment.

## INSIDE THE S30

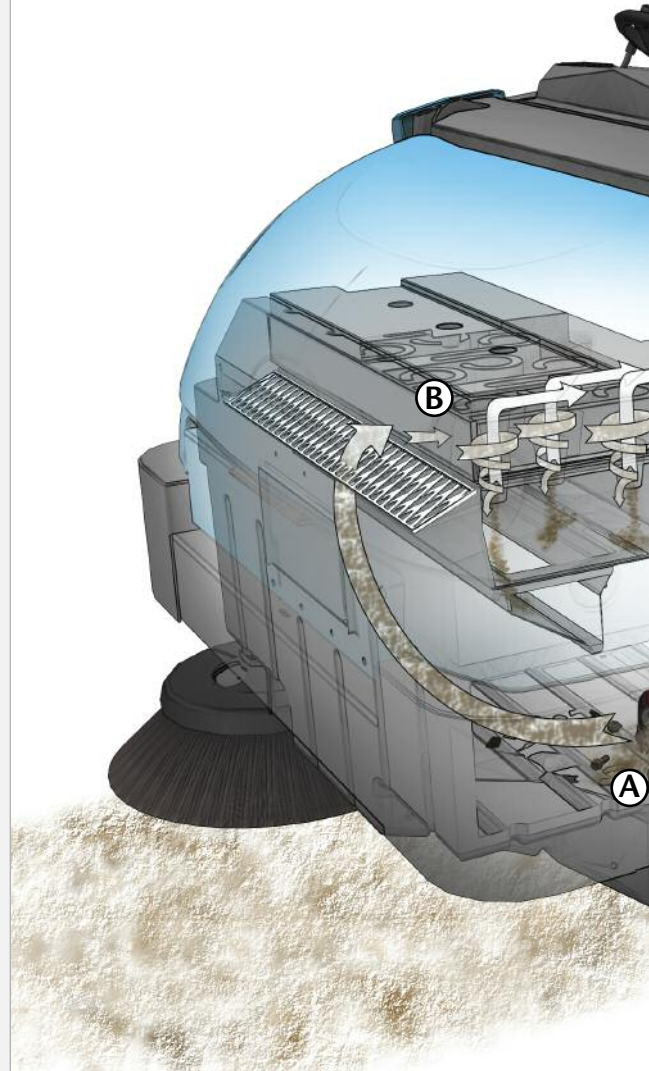

**A**

Ensure operator safety, by alerting and shutting down sweeping functions, if increases in hopper temperature are sensed by Thermo-Sentry™.

**B**

Provide air flow filtration and dry dust control for sweeping all floor surfaces with the SweepSmart™ system.

## KEY AVAILABLE FEATURES



Achieve outstanding results in the harshest environments with dual side brushes which, combined with a large 14 ft<sup>3</sup> / 395 L Duramer™ hopper, allow you to sweep up to 80 in / 2,030 mm in a single pass.



Minimize risk of damage to both the machine frame and the facility with rounded rear corners and rear tower bumpers that improve turn off from structures (walls and racking), while protecting from accidental contact.



Increase safety and effective operation, in even the most severe environments, with an optional FOPS certified (ISO 3449) pressurized cabin available with heat and air conditioning.

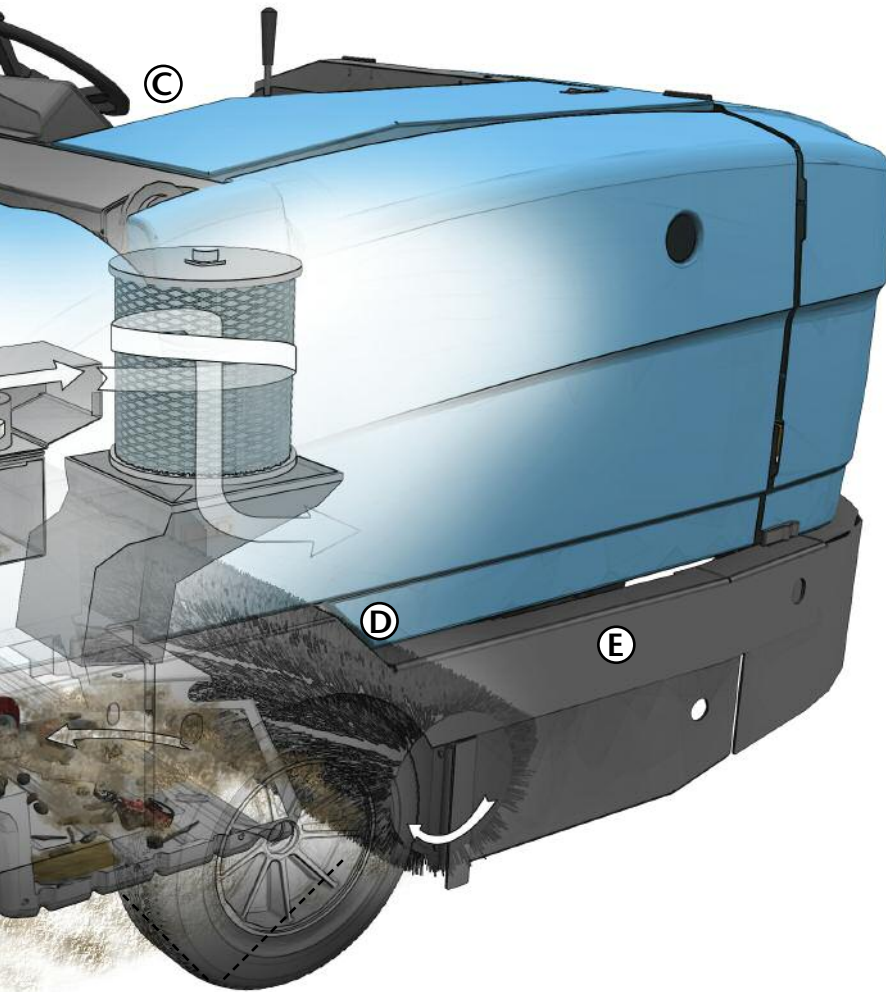

**C**

Effectively remove different types of debris with the II-Speed™ sweep system. This increases the speed of the main brush, side brush, and vacuum fan by 20%.

**D**

Improve sweeping results with the retractable, spring loaded flap that re-circulates any debris that may escape over the main brush.

**E**

Depend on long-term structural reliability with a heavy-gauge steel machine frame designed for greater strength, rigidity, and long life.

# S30 SWEEPERS

	RESULT	FEATURE
Increased Safety	Improves visibility and response time to obstacles	Cab forward ErgoSpace™ operator compartment
	Reduces the risk of accidental hopper fires	Thermo-Sentry™ hopper sensor
	Independent laboratory certification for global safety compliance	Underwriter’s Laboratory (UL®) Certified
	Reduces fatigue and environment noise levels	Lowest noise level for an engine-powered sweeper in this class at 80 dBA
Reduced Costs	Quick, easy maintenance, allows maximum uptime	EasyOpen™ service access and on-board diagnostics
	Reduces hydraulic temperatures and increases component life	Large-capacity hydraulic oil tank, triple accessory pumps, and micro component in-line filter to provide consistent hydraulic flow and pressure
	Reduces unnecessary downtime and wheel maintenance	Soft ride, solid tires have a significantly higher load capacity, remarkable durability and low maintenance
	Reduces maintenance costs and increases effective cleaning performance	Large spline drive that transfers power deep into the brush core, integrated string and twine guard, and Tennant’s patented color coded brush wear indicator
Maximum Productivity	Maximizes dust control while sweeping	SweepSmart™ 3-stage dust control system provides improved air flow filtration and dust control
	More effectively sweep different types of debris by increasing the main brush, side brush, and vacuum fan speeds up to 20%.	II-Speed™ Sweeping
	Decreases operator training time and simplifies machine operation	Touch-N-Go™ operation with simple 1-STEP™ sweeping begins all operations, remembering previous settings
	Improves handling and patrol sweeping capability	Dynamic steering responsiveness, rear suspension system, and 4-wheel stability for spot cleaning with the S30 X4 model





## S30 RIDER SWEEPER

### SPECIFICATIONS

#### Sweeping System

Cleaning path		
Single side brush	62.5 in	1,590 mm
Dual side brush	80 in	2,030 mm
Main brush		
Main brush length (tubular)	45 in	1,145 mm
Main brush lift	Mechanical or Hydraulic	
Main brush change	No-tool	
Side broom		
Side broom diameter	26 in	660 mm
Debris hopper		
Volume capacity	14 ft <sup>3</sup>	395 L
Weight capacity (plastic)	1,080 lb	490 kg
Weight capacity (steel)	1,200 lb	545 kg
Dump height (variable to)	60 in	1,525 mm
Dump reach	30 in	760 mm

#### Dust Control System

Filter system (triple stage)		
Stage 1	Perma-Filter™	
Stage 2	Cyclonic pre-filter	
Stage 3	Nanofiber canister filter	
Filter area	80.8 ft <sup>2</sup>	7.5 m <sup>2</sup>
Dust filtration (up to)	0.5 microns @ 99% efficiency	
Vacuum fan speed		
Normal sweeping mode	4600 rpm	4600 rpm
Litter sweeping mode	5500 rpm	5500 rpm
Vacuum diameter	11 in	280 mm

#### Propelling System

Propel speed forward (variable to)	10/15 mph	16/24 km/h
Propel speed reverse (variable to)	3 mph	5 km/h
Engine-gasoline/LPG	55 hp GM	41 kW GM
Engine-diesel	37.5 hp Kubota	28 kW Kubota
Gradeability		
Full hopper	10 deg/18%	10 deg/18%
Empty hopper	14 deg/25%	14 deg/25%
Ground clearance	4 in	100 mm

#### Machine Dimensions

Length	93 in	2,360 mm
Width	62.5 in	1,590 mm
Height		
With overhead guard	82.5 in	2,095 mm
Without overhead guard	58 in	1,475 mm
Weight (net)	3,520 lb	1,595 kg
Minimum aisle turn	113 in	2,870 mm
Sound level	80 dBA	80 dBA

## GENUINE TENNANT PARTS, SUPPLIES & SERVICE

### Genuine Tennant Parts Advantage

Operate your machine with confidence by choosing genuine Tennant parts. Only authentic Tennant parts are engineered in conjunction with Tennant equipment. For years of worry-free operation, accept only genuine parts and supplies.

### Industry's Only Factory-Direct Service Network

Providing world-class response, completion times and on-site machine service, our factory-trained network of 450 service techs are dedicated to keeping your cleaning program up and running.

*Choose financing options through Tennant for simple, quick financing with flexible upgrade options, and no long-term obligation. Financing is offered through Tennant Financial® Services and Tennant Capital® Services.*

## WARRANTY

All parts (excluding batteries) have a 48 month warranty under normal use and service, and 6 months on-site service labor coverage of warranty items and travel.

## SEEING IS BELIEVING

See for yourself how the S30 sweeper delivers clean, safe floors. For a demonstration or additional information, call 800.553.8033.

## Your Authorized Dealer is:

### Municipal Equipment Sales, Inc.

Mailing Address: PO Box 1233  
Location: 208 Bell Place  
Woodstock, GA 30188

Local: 770-928-0424  
Fax: 770-928-7512  
Nationwide Toll Free: 1-800-782-2243  
Email: sales@municipalequipment.com  
Web: www.municipalequipment.com

